

FBV-133T三片式不銹鋼高壓球閥

產品特徵：

SPECIFICATIONS

*公稱壓力：1/4" ~2" 210kgf/cm²

Working Pressure: 1/4" ~2" 3000PSI

*適用溫度範圍：-20 ~ 260°C

Temperature Range: -20 ~ 260°C

*連接形式：內螺紋/對焊/承插焊

End Types: Female Threaded/Butt Weld/Socket Weld

*防爆中軸設計

Blow-Out Proof Stem Design

*防火安全設計 Fire safe

*注：如需全通徑高壓球閥或者金屬硬密封高壓球閥，請另行諮詢

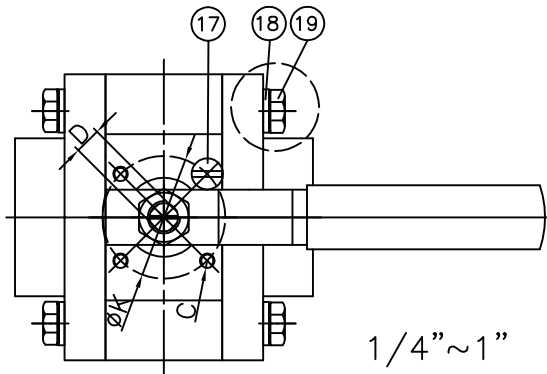

型號：FBV-133T

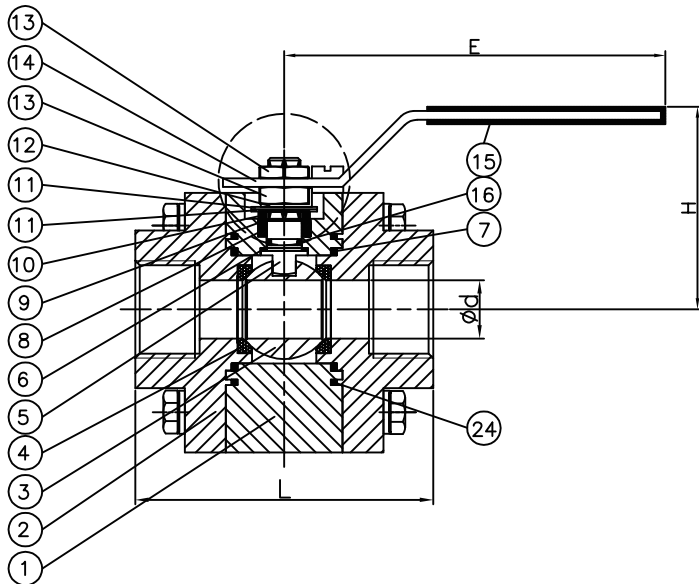
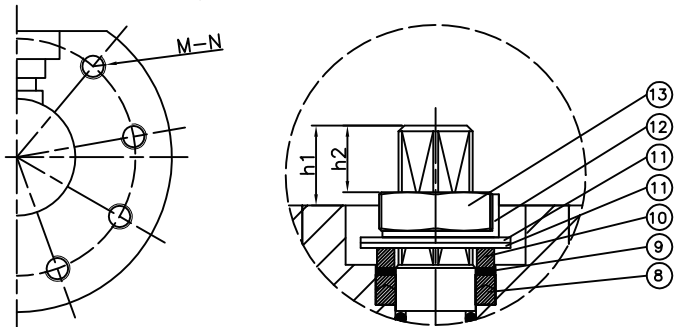

DIMENSION

unit: mm

SIZE	d	L	E	H	D	K	C	h1	h2	N	M
1/4"	9.5	85	151	61	9	36	M5	10.1	7	6	5/16-18UNC
3/8"	11.6	85	151	61	9	36	M5	10.1	7	6	5/16-18UNC
1/2"	12.5	85	151	61	9	36	M5	10.1	7	6	5/16-18UNC
3/4"	16	89	151	67	9	42	M5	14.85	10.3	8	5/16-18UNC
1"	20	102	183	81	9	42	M5	12	10	8	5/16-18UNC
1 1/4"	25	111	183	97	11	42	M5	22.3	11.5	8	5/16-18UNC
1 1/2"	32	119	285	113	14	50	M6	33.2	17.5	8	3/8-16UNC
2"	38	126	285	117	14	50	M6	28	17.5	8	1/2-13UNC

MATERIALS LIST

NO	DRAW NO	PART NAME	MATERIAL	QTY	
				AI316	AI31025
1	01	BODY	AI316/AI31025	1	1
2	02	CAP	AI316/AI31025	2	2
3	03	BALL	ASTM A351 Gr.CF8M	1	1
4	04	BALL SEATS	Derlin/Peek	2/1 SETS	2/1 SETS
5	05	STEM	17-4PH	1	1
6	06	THRUST WASHER	Derlin/Peek	1	1
7	07	END SEALS	Derlin/Graphite	2/1 SETS	2/1 SETS
8	08	STEM PACKING	25% Carbon Filled	1 SETS	1 SETS
9	09	THRUST WASHER	TFM1600	1	1
10	10	GLAND BUSH	S.S.304	1	1
11	11	BELLEVILLE WASHER	SUS304-CSP	2	2
12	12	STOP	S.S.304	1	1
13	13	HANDLE NUT	S.S.304	2	2
14	14	HANDLE	S.S.304	1	1
15	15	HANDLE SLEEVE	VINYL GRIP	1	1
16	16	O-RING	VITON	1	1
17	17	STOPPER	S.S.304	1	1
18	18	SPRING WASHER	S.S.304/S45C	12~16	12~16
19	19	BOLT	A2-70/SCM440	12~16	12~16
20	20	STOP PLATE	S.S.304	1	1
21	21	STEM ADAPTER	S.S.304	1	1
22	22	NUT	A2-70	2	2
23	23	BOLT	S.S.304	2	2
24	24	END SEALS	PTFE	2/1 SETS	2/1 SETS
25	25	NUT	S45C	0	12~16